

This Page Is Inserted by IFW Operations
and is not a part of the Official Record

BEST AVAILABLE IMAGES

Defective images within this document are accurate representations of the original documents submitted by the applicant.

Defects in the images may include (but are not limited to):

- BLACK BORDERS
- TEXT CUT OFF AT TOP, BOTTOM OR SIDES
- FADED TEXT
- ILLEGIBLE TEXT
- SKEWED/SLANTED IMAGES
- COLORED PHOTOS
- BLACK OR VERY BLACK AND WHITE DARK PHOTOS
- GRAY SCALE DOCUMENTS

IMAGES ARE BEST AVAILABLE COPY.

**As rescanning documents *will not* correct images,
please do not report the images to the
Image Problem Mailbox.**

PATENT ABSTRACTS OF JAPAN

(11)Publication number : **10-068729**
 (43)Date of publication of application : **10.03.1998**

JP-10-068729

(51)Int. Cl. **G01N 33/537**
B01D 39/10
B01J 19/00

(21)Application number : 08-244042	(71)Applicant :	IATRON LAB INC
(22)Date of filing : 28.08.1996	(72)Inventor :	SUZUKI KOICHI ARAO SHINSUKE SHIMAMOTO KAZUTOSHI SOFUE SUSUMU NAKATSUKA YOKO KUDO KATSUHIRO WADA TATSUO

(54) REACTION CONTAINER

(57)Abstract:

PROBLEM TO BE SOLVED: To obtain a reaction container comprising a filtering material of high proof stress in usage, by using a metallic mesh filtering material manufactured by the electrocasting method, and having a pore of a specific diameter.

SOLUTION: The desired shape of a filtering material is accurately plotted onto a drum film type-photos resist by a computer or the like and is laminated onto the surface of a cathode of a stainless plate. Then the same is made to sense the light by using a negative film, and developed, to form a resist pattern onto the surface, and further is washed by a surface active agent, and finished by the pure water. Then it is dipped into, for example, a watt bath type for activating the stainless plate surface of an area not having the resist pattern, and the predetermined electric current is flow made to from a cathode power supply. When the film reaches a predetermined thickness by the electrocasting, the electric current is cut off, and the stainless plate is taken out to be washed by the water. Then the nickel electrocasted plating formed on the stainless plate is separated to be used as the filtering material through the necessary processing. As mentioned in the above, the filtering material having, for example, a pore of 20-500 μ m, and an uniform diameter or length of one side, can be manufactured.

LEGAL STATUS

[Date of request for examination] 22.11.2002

[Date of sending the examiner's decision of rejection]

[Kind of final disposal of application other than the examiner's decision of rejection or application converted registration]

[Date of final disposal for application]

[Patent number]

[Date of registration]

[Number of appeal against examiner's decision of rejection]

[Date of requesting appeal against examiner's decision of rejection]

[Date of extinction of right]

* NOTICES *

Japan Patent Office is not responsible for any damages caused by the use of this translation.

1. This document has been translated by computer. So the translation may not reflect the original precisely.
2. **** shows the word which can not be translated.
3. In the drawings, any words are not translated.

CLAIMS

[Claim(s)]

[Claim 1] The reaction container characterized by providing the metal mesh (wire gauze) manufactured by electroforming as a filter medium.

[Claim 2] The reaction container characterized by providing the metal mesh (wire gauze) which has the uniform pore a diameter or whose length of one side is 20 micrometers - 500 micrometers, and which was manufactured by electroforming as a filter medium.

[Translation done.]

* NOTICES *

Japan Patent Office is not responsible for any damages caused by the use of this translation.

1. This document has been translated by computer. So the translation may not reflect the original precisely.
2. **** shows the word which can not be translated.
3. In the drawings, any words are not translated.

DETAILED DESCRIPTION

[Detailed Description of the Invention]

[0001]

[The technical field to which invention belongs] this invention relates to the reaction container possessing a metal mesh (network). Furthermore, by making the metal mesh (network) manufactured by the reaction container with electroforming provide as a filter medium in detail, as the ** exception (prehension) of the particle in a reaction container can be performed exactly, it is related with the reaction container which enabled it to measure correctly the measuring object matter combined with the aforementioned particle within this reaction container.

[0002]

[Description of the Prior Art] In medicine or the site of environmental measurement, pressure of business of the technology which measures the quality of the specified substance in a sample mechanically and automatically using an antigen-antibody reaction has been carried out. for example, the detailed particles (latex particle which consists of a synthetic macromolecule) which combined the immunological partner of the quality of the specified substance and a specimen (blood --) These processing liquid, such as a blood serum, plasma, urine, feces suspension, pharynx *****, cerebrospinal fluid, and a cell extract After making it react by making it mix and contact within glass or the container of a macromolecule (the first reaction), Add another [which combined the matter (an enzyme, a photogene, fluorescent substance, etc.) which discovers a signal detectable to this] immunological partner, he is made to react (the second reaction), the signal of the marker origin is detected, and there are quality and the method of measuring quantitatively about the quality of the specified substance.

[0003] Although the above-mentioned reaction is usually performed within a reaction-of-identity container, it is necessary to dissociate from sample liquid (sample), and to acquire and set the very fine particle which the quality of the specified substance after the first reaction end combined at this time in a reaction container (making it remain). Furthermore, although it is necessary to carry out washing removal of the interfering substance which remains, it is necessary to acquire and set the very fine particle which the quality of the specified substance combined also in this case in a reaction container (making it remain). As the means, from opening of a container, attract a liquid and it discards, or the filter medium which has the pore which a very fine particle does not pass to the other end is arranged, from the embarrassment section, it draws in from the lower part of pressurization or a filter medium, and a liquid is discarded. Although it progresses to the following reaction distance after that, in order to make a detectable signal discover if needed, same abandonment / washing process is performed again.

[0004] By the way, although centrifugal is carried out beforehand, and it is necessary to settle a particle and to fix magnetically using a magnetic particle in suction abandonment so that a very fine particle may not be attracted, either, for the reason, the mechanism of an incidental machine becomes complicated, or there are problems, like a special particle is needed. On the other hand, although the mechanism of an incidental machine becomes complicated a little, since a special particle does not need to be used for the method using the reaction container which prepared the filter medium and it can also omit the mechanism for it, it may be convenient. this application tries improvement of a reaction container which prepared the filter medium in consideration of the above point.

[0005]

[The technical problem which should be solved] Now, that across which it goes as a filter medium of the above-mentioned reaction container more variably than before has been used. That is, they are the filter paper which consists of paper, absorbent cotton, a powdered filter paper, the filter that knit the fiber metallurgy group in the shape of a mesh, nature, the porosity object of a synthetic macromolecule, or the sintered compact of inorganic and *****. However, it has uniform pore applicable to precision analysis especially in recent years, and the need of the filter which was excellent in intensity is increasing. The reason is because it is necessary to make the very detailed matter exact a ** exception like the matter (an erythrocyte, virus, etc.) contained in a microorganism or living body liquid on the occasion of analysis of a minute amount biogenic substance like an antigen-antibody reaction (for example, a hole with a high precision of about $\phi = 20$ micrometers is required to remove an erythrocyte). In such a case, if passage of the liquid phase or the gaseous phase itself is difficult even if it gives priority to the function according to **, it must not be practical, and the resistance of the filter medium itself must also be still higher.

[0006] Moreover, in the case of the filter medium used for the above-mentioned precision analysis, if waste fluid and an impurity pile up into a filter medium or the particle which the quality of the specified substance combined is buried in pore, it will become the error factor of a measurement result. Therefore, what has the uniform aperture of **** is required of the filter medium of a reaction container as thinly [the thickness] as possible. However, it was impossible to have filled such all functions with the conventional filter medium.

[0007] Then, an artificer etc. has uniform pore, the resistance at the time of use is excellent, and as a result of inquiring wholeheartedly for the purpose of offer possessing the filter medium which does not interfere in the target system of reaction of a reaction container, he completed this invention.

[0008]

[Means for Solving the Problem] The invention in this application was made in order to solve the above trouble, and it is constituted by a following claim 1 and a following claim 2.

Claim 1: The reaction container characterized by providing the metal mesh (wire gauze) manufactured by electroforming as a filter medium.

Claim 2: The reaction container characterized by providing the metal mesh (wire gauze) which has the uniform pore a diameter or whose length of one side is 20 micrometers - 500 micrometers, and which was manufactured by electroforming as a filter medium.

[0009] Electrocasting here (electrotyping) A method is the method of the common knowledge which reproduces the same thing as a prototype precisely using electrodeposition by electrolysis so that a casting may be built with mold. This technology is already applied in many fields, and it is applied to the manufacture methods (JP,2-159789,A, JP,6-152105,A, etc.) of of the field which manufactures precision electronic parts, for example, a printed wired board, especially in recent years. this application ** the metalworking article which has the pore which consists of specific thickness and specific aperture by this method, and is related with the reaction container which possesses this as a filter medium. It is electrocasting (electrotyping), when the artificer applied a trial-and-error method to many things and inquired. When using the metal mesh (wire gauze) manufactured by the method as a filter medium, it became clear that the ** exception (prehension) of the particle in a reaction container can be exactly performed as compared with other filter media. Moreover, the metal mesh (wire gauze) manufactured with electroforming is easy to be obtained as what has the range of 20 micrometers - 500 micrometers with uniform diameter or length of one side.

[0010] Next, the manufacture method of this filter medium is explained briefly.

** First, by computer, it is accurate for a dry film type photoresist, and plot precisely the configurations (the whole size, size of pore, etc.) of a filter medium demanded to it.

** For example, a surface average rough degree laminates this photoresist in the cathode surface of the stainless steel board (specifically SUS 304 grade) of suitable thickness prepared by 0.08-0.10 micrometers.

** Subsequently, do sensitization and development of using a negative film, and form a resist pattern in this front face.

** Finish with pure water further after washing with a well-known surfactant (it washes).

** Flood this for example, with a Watts-bath type, activate the stainless steel board front face of a portion without a resist pattern, and connect a cathode power supply. Predetermined current density is ****(ed), and electrocasting is continued until it becomes regular thickness.

** If predetermined thickness is formed, a power supply will be shut off, and pick out a stainless steel board from a bathtub.

** Rinse this stainless steel board enough, tear off physically the nickel **** mesh formed in the stainless steel board, carry out required processing (for example, it pierces in the target size), and manufacture the target filter medium.

[0011] The aforementioned Watts bath consists of a nickel sulfate, a nickel chloride, a boric acid, various additives, a pit prevention agent, and pH 3.0-3.5, and electrolysis nickel and temperature are [the conditions of electrocasting / an electrode] 50-55 degrees C and current density 2.5 - 4.5 A/dm² It sets up and carries out under stirring.

[0012] It can change to the aforementioned Watts bath and a sulfamic-acid nickel type can also perform. This consists of a nickel amiosulfonate, a boric acid, various additives, a pit prevention agent, and pH 4.0-4.8, and, for an electrode, depository RAIZUDO (double pole) nickel and temperature are [the conditions of electrocasting] 48-50 degrees C and current density 2.0 - 4.8 A/dm² It can set up and can also carry out under stirring.

[0013] Thus, the manufactured filter medium can be manufactured to an about 20-micrometer thing with the diameter of the minimum. It is possible to form the filter medium which can manufacture suitably by within the limits to 25 micrometers - 500 micrometers, and has a uniform hole within the limits of the above especially also on the upper surface and the inferior surface of tongue of a filter medium. 1 micrometers or more also of the thickness can also be especially manufactured suitably to 2 micrometers - 500 micrometers. About the quality of the material, the filter medium which consists of metals, such as nickel, copper, zinc, aluminum, titanium, cobalt, gold, and silver, can be obtained that what is necessary is just a metal applicable to electroforming.

[0014] Un-electrolyzing and electrolysis plating of platinum, gold, silver, etc. can also be further given for the aforementioned filter medium by the usual means. Since especially the filter medium of this application is a metal, it is excellent so in [that the resistance at the time of use does not become that thickness is very as thin as several micrometers as compared with the quality of the material like the conventional synthetic macromolecule] intensity. Moreover, like a sintered-compact filter, since thickness is thin, since waste fluid does not remain in *****, it excels also in the pollution control.

[0015] Moreover, since aperture of pore can be specified and created by the plot by the computer, and it has an aperture with all uniform holes, and the target matter is made a ** exception exactly and it can prevent that a particle is also buried, the reliability of a measurement result can be raised.

[0016] Furthermore, since the metal applicable to the **** method is wide range, the suitable metal which does not affect especially an immunological reaction can be chosen.

[0017]

[Embodiments of the Invention] Thus, the manufactured filter medium is conventionally applied to the filter medium of a well-known reaction container. A reaction container is a container which can hold the liquid which consists of glass or a

macromolecule, and fixes the aforementioned filter medium to the part which waste fluid passes at least with suitable means (sticking by pressure, fitting, etc.). The example of - of this application reaction container (the quality of the material of a main part is synthetic resin) is shown in drawing 1.

[0018] as the example of use -- the first container upper part after a reaction -- air -- pressurizing -- the liquid after a reaction end -- waste fluid passage -- it discharges from a hole A penetrant remover is added if needed and a penetrant remover is discharged similarly. The second reaction is carried out succeeding. The particle which the quality of the specified substance combined is caught with a filter medium, and the second reaction and a signal manifestation reaction are carried out under the situation that there are not sufficient washing and impurity.

[0019]

[Example]

The grid view was plotted to the dry film type photoresist so that the aperture of the manufacture (1) pore of a <example 1> filter-medium possession reaction container might be set to 50 micrometers. The surface average rough degree laminated this photoresist in the cathode surface of the stainless steel board (SUS 304) prepared by 0.09 micrometers. Subsequently, sensitization and development of were done using the negative film, and the resist pattern was formed in this front face. The surfactant washed with pure water further after washing a front face. This was immersed in pH 3.3 Watts bath containing a nickel sulfate (350 g/l), a nickel chloride (45 g/l), a boric acid (35 g/l), the saccharin (7 g/l) as an additive, and the sodium lauryl sulfate (1 g/l) as a pit prevention agent, the stainless steel board front face of a portion without a resist pattern was activated, and the cathode power supply was connected. Subsequently, as conditions for electrocasting, an electrode is electrolysis nickel and temperature is 50-55 degrees C and current density 2.8 A/dm² It set up and electrocasting was performed under stirring. After continuing electrocasting until thickness was set to 10 micrometers, the power supply was shut off, the stainless steel board was picked out from the bathtub, this stainless steel board was rinsed enough, the nickel electrocasting mesh formed in the stainless steel board was torn off, it pierced in a circle with a diameter of 7.5mm, and pore aperture obtained 50 micrometers and the filter medium (refer to photograph) with a thickness of 10 micrometers. The above-mentioned filter medium was inserted and stuck to the reaction container of the size succeeding shown in drawing by pressure from the opening side, and it considered as the filter-medium possession reaction container.

[0020] After adding 100micro of Homo sapiens blood l of 50% of MATOKURITSUTO values in the filter possession reaction container concerned to the filtration-efficiency comparison examination by <example 2> this use [filter], blood was discharged out of the system through the filter with pressurization air from the container upper part. Next, 500micro of physiological salines l is put in from the reaction container upper part, and it began to pass through the filter with pressurization air. Furthermore, the same operation was repeated twice by the physiological saline, finally 1ml of distilled water was put into the container, and it stirred for 10 minutes lightly. 1ml in this container was taken out and the amount of hemoglobin (what was eluted from the erythrocyte) which measured the absorbance in the wavelength of 420nm with the spectrophotometer, and remained on the filter was computed. The result of 0.2 ** 0.1 mg/dl (Mean**1SD) was obtained by 10-fold measurement. Using what equipped the aforementioned reaction container with the conventional elasticity filter medium (2mm in the product made from polyethylene, and thickness, 50 micrometers of average pore size) as an object, the same operation as the above was performed and the hemoglobin residue in a reaction container was computed. The result of 10.4**3.2 mg/dl (Mean ** 1SD) was obtained by 10-fold measurement. From the above-mentioned result, it was checked that the thing with the almost same average pore size for which an erythrocyte is nevertheless passed completely is possible for the filter of this application compared with the conventional elasticity filter.

[0021] The anti-HBs antibody was filtered after addition and 2-hour stirring to 10% suspension of polystyrene PIZU (Sekisui Chemical make) of 100 micrometers of performance comparison examination mean particle diameters in the amount measurement of hepatitis B surface antigen by <example 3> this use [filter], and the anti-HBs antibody coat bead was obtained. This bead 5mg was put into the above-mentioned filter wearing reaction container concerned, and ** was carried out for upper opening with the aluminum seal. Apart from this, the acridinium ester which is a photogene was combined with the anti-HBs antibody as a marker, and the indicator anti-HBs antibody was produced. This indicator object was diluted to pH 7.5 phosphate buffer solution, and was made into the second antibody. As sample liquid, using hepatitis-B-surface-antigen negative and electropositive Homo sapiens blood, as a measuring device, full automatic luminescence immunoassay equipment (tradename : RUMIKUIKKU JIA-FS150, JEOL make) was used, and the following operations were performed. In addition, when the amount of hepatitis B surface antigen in the blood of these two samples was measured by APOTSUTO OSUZAIMURO, it was 3.0U/ml in 0.0U/ml and the sample 2 by the sample 1. the above-mentioned bead as a reagent used on a machine, and NI -- the luminescence reagent which are a penetrant remover containing the surfactant and an alkaline-water solution containing hydrogen peroxide solution required for making light emit was prepared and used in addition to degree antibody

[0022] After tearing the up aluminum seal of this filter possession reaction container set on the RUMIKUIKKU machine, poured in the 100micro of the above-mentioned Homo sapiens blood serums l, and it was made to react with a bead for 3 minutes at 37 degrees C, and washing drainage was performed 4 times by the penetrant remover after that, and, next, the container was filled with 100micro of NI degree antibodies l. Four washing drainage was carried out after 37 degrees C and stirring for 5 minutes. Succeedingly, a reaction container is automatically conveyed by the luminescence test section, 400micro of luminescence reagents l is poured in at it, and a luminous reaction starts. The fixed quantity of the amount of hepatitis B surface antigen in the Homo sapiens blood concerned was carried out from the amount of luminescence which measured this amount of luminescence by the photon counter, and measured as a sample the blood which contained the hepatitis B surface antigen of a known amount independently. It measured by a unit of 10 times about the blood of two samples, respectively, and the result of Table 1 was

obtained.

[0023]

[Table 1]

本発明フィルターを用いた測定

No.	検体1	検体2
1	0. 0U/ml	3. 2U/ml
2	0. 0	3. 1
3	0. 0	3. 2
4	0. 0	3. 0
5	0. 0	3. 1
6	0. 0	3. 1
7	0. 1	3. 1
8	0. 1	3. 2
9	0. 0	3. 1
10	0. 0	3. 2
Mean	0. 02	3. 13
SD		0. 0675
CV%		2. 16

[0024] Moreover, the same operation as the above was carried out using what built the elasticity filter (2mm in the product made from polyethylene, 50 micrometers of average pore size, thickness) into the aforementioned reaction container as an object, and the result of Table 2 was obtained.

[0025]

[Table 2]

従来のフィルターを用いた測定値

No.	検体1	検体2
1	0. 0U/ml	3. 4U/ml
2	0. 1	2. 8
3	0. 2	3. 3
4	0. 0	3. 1
5	0. 0	3. 0
6	0. 1	2. 7
7	0. 0	3. 5
8	0. 2	3. 3
9	0. 2	3. 0
10	0. 1	3. 0
Mean	0. 09	3. 11
SD		0. 260
CV%		8. 36

[0026] As mentioned above, the result measured with the container possessing the filter concerned hardly changed the measured value itself compared with the conventional elasticity filter (there is no influence on system of measurement), but it was checked that repeatability is moreover rising sharply.

[0027]

[Effect of the Invention] Since the reaction container of the invention in this application was constituted as mentioned above, waste fluid and an impurity can pile up into a filter medium, or the particle which the quality of the specified substance combined can be buried in pore, and it can solve the conventional trouble of producing the error of a measurement result, to - **. moreover, the filter medium manufactured with electroforming -- the manufacture method itself -- it is simple, and excels in intensity conventionally as compared with elegance, and a performance can be made uniform Furthermore, since the ** exception (prehension) of the target matter can be performed exactly, it becomes applicable in a latus field.

[Translation done.]

filter

DERWENT-ACC-NO: 1998-225873

DERWENT-WEEK: 199820

COPYRIGHT 1999 DERWENT INFORMATION LTD

TITLE: Reaction container for qualitative assay of sample - for
e.g. medical or environmental testing, has electroformed
metal mesh which acts as filter medium

JP 10-068729

PATENT-ASSIGNEE: IATRON LAB INC[IATR]

PRIORITY-DATA: 1996JP-0244042 (August 28, 1996)

PATENT-FAMILY:

PUB-NO	PUB-DATE	LANGUAGE	PAGES	MAIN-IPC
JP 10068729 A	March 10, 1998	N/A	007	G01N 033/537

APPLICATION-DATA:

PUB-NO	APPL-DESCRIPTOR	APPL-NO	APPL-DATE
JP 10068729A	N/A	1996JP-0244042	August 28, 1996

INT-CL (IPC): B01D039/10, B01J019/00, G01N033/537

ABSTRACTED-PUB-NO: JP 10068729A

BASIC-ABSTRACT:

Reaction container (1) for qualitative analysis has a metal mesh (2) formed by electroforming, which acts as filter medium. The metal mesh preferably has uniform pores with diameter of about 20-500 μ m.

USE - The device is useful for e.g. medical or environmental testing and may be used for analysing samples such as blood, serum, plasma, urine, faeces suspension, pharyngeal wiping mucus, cerebrospinal fluid and cell extract.

ADVANTAGE - The applicability of the device is increased and fine particles are efficiently filtered off.

CHOSEN-DRAWING: Dwg.1/3

TITLE-TERMS: REACT CONTAINER QUALITATIVE ASSAY SAMPLE MEDICAL ENVIRONMENT TEST
ELECTROFORMING METAL MESH ACT FILTER MEDIUM

ADDL-INDEXING-TERMS:

BLOOD SERUM PLASMA URINE

DERWENT-CLASS: B04 J04 S03

CPI-CODES: B11-C; J04-B01;

EPI-CODES: S03-E14H4;

CHEMICAL-CODES:

Chemical Indexing M1 *01*

Fragmentation Code

M423 M424 M740 M760 M903 N101 V600 V614 V615 V632

V633 V754

Chemical Indexing M6 *02*
Fragmentation Code
M903 P831 R770

SECONDARY-ACC-NO:

CPI Secondary Accession Numbers: C1998-071034

Non-CPI Secondary Accession Numbers: N1998-179363

(19) 日本国特許庁 (J P)

(12) 公開特許公報 (A)

(11) 特許出願公開番号

特開平10-68729

(43) 公開日 平成10年(1998) 3月10日

(51) Int.Cl. ⁸	識別記号	庁内整理番号	F I	技術表示箇所
G 0 1 N	33/537		G 0 1 N	33/537
B 0 1 D	39/10		B 0 1 D	39/10
B 0 1 J	19/00		B 0 1 J	19/00
				G

審査請求 未請求 請求項の数 2 F D (全 7 頁)

(21) 出願番号 特願平8-244042

(22) 出願日 平成 8 年(1996) 8 月28日

(71) 出願人 000138277
株式会社ヤトロン
東京都千代田区東神田 1 丁目11番 4 号

(72) 発明者 鈴木 光一
東京都千代田区東神田 1 丁目11番 4 号 株
株式会社ヤトロン内

(72) 発明者 荒尾 進介
東京都千代田区東神田 1 丁目11番 4 号 株
株式会社ヤトロン内

(72) 発明者 嶋本 三利
東京都千代田区東神田 1 丁目11番 4 号 株
株式会社ヤトロン内

(74) 代理人 弁理士 今野 耕哉 (外 1 名)
最終頁に続く

(54) 【発明の名称】 反応容器

(57) 【要約】

【課題】 本発明は、測定対象物質を結合した微細な粒子等を効率よく濾過できるようにした金属メッシュ（網）を具備する反応容器に関する。

【解決手段】 (1) 電鍍法によって製造された金属メッシュ（金網）を濾過材として具備することを特徴とする反応容器。

(2) 直径又は一辺の長さが、 $20\mu\text{m}$ ~ $500\mu\text{m}$ の均一な細孔を有する、電鍍法によって製造された金属メッシュ（金網）を濾過材として具備することを特徴とする反応容器。

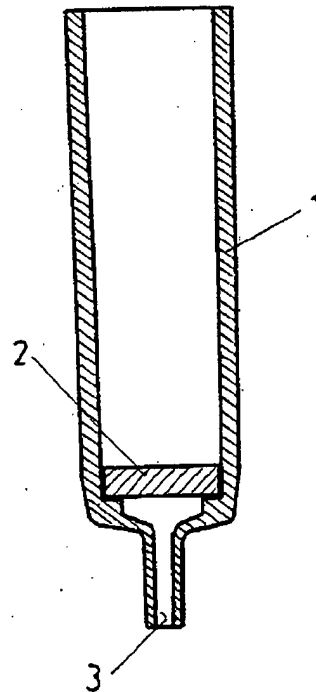

1

【特許請求の範囲】

【請求項1】 電鍍法によって製造された金属メッシュ（金網）を濾過材として具備することを特徴とする反応容器。

【請求項2】 直径又は一辺の長さが20 μ m～500 μ mの均一な細孔を有する、電鍍法によって製造された金属メッシュ（金網）を濾過材として具備することを特徴とする反応容器。

【発明の詳細な説明】

【0001】

【発明の属する技術分野】本発明は金属メッシュ（網）を具備する反応容器に関する。更に詳しくは、反応容器に電鍍法によって製造された金属メッシュ（網）を濾過材として具備させることにより、反応容器内の微粒子の濾別（捕捉）を的確に行うことができるようにして、前記微粒子に結合している測定対象物質を、この反応容器内で正確に測定することができるようにした反応容器に関するものである。

【0002】

【従来の技術】医療や環境測定の現場等では、抗原抗体反応を利用して試料中の目的物質を機械的、自動的に測定する技術が繁用されてきている。例えば、目的物質の免疫学的パートナーを結合した微細な粒子（合成高分子からなるラテックス粒子等）と被検試料（血液、血清、血漿、尿、糞便懸濁液、咽頭拭い液、髄液、細胞抽出液等あるいはこれらの処理液）とを、ガラスや高分子の容器内で混合・接触させて反応（第一の反応）させた後、これに検出可能な信号を発現する物質（酵素、発光物質、蛍光物質等）を結合したもう一方の免疫学的パートナーを加えて反応（第二の反応）させ、その標識物質由来の信号を検出して目的物質を定性・定量的に測定する方法がある。

【0003】上記の反応は通常同一反応容器内で行われるが、この際第一の反応終了後の、目的物質が結合した微細粒子を、被検液（試料）から分離し、反応容器内に取得して（残存させて）おく必要がある。また更に、残存する干渉物質を洗浄除去する必要があるが、この場合にも目的物質が結合した微細粒子を反応容器内に取得して（残存させて）おく必要がある。その手段としては、容器の開口部より液体を吸引して廃棄したり、他端に微細粒子が通過しない細孔を有する濾過材を配設し、閉口部より加圧あるいは濾過材の下部より吸引して液体を廃棄したりする。その後次の反応行程に進むが、必要に応じて検出可能な信号を発現させるために、再度同様の廃棄・洗浄工程が行われる。

【0004】ところで吸引廃棄の場合には、微細粒子も吸引されないように、予め遠心して粒子を沈殿させておいたり、また磁性の粒子を用いて磁石で固定しておく必要があるが、そのために付帯機械の機構が複雑になったり、特殊な粒子が必要となる等の問題がある。一方、濾

2

過材を設けた反応容器を用いる方法は、付帯機械の機構は若干複雑になるが、特殊な粒子を用いる必要がなく、そのための機構も省略できるため都合が良い場合もある。本願は、以上の点を考慮して濾過材を設けた反応容器の改良を試みたものである。

【0005】

【解決すべき課題】さて、上記反応容器の濾過材としては、従来より多岐に渡るものが用いられてきた。すなわち、紙からなる濾紙、脱脂綿、粉末状の濾紙、繊維や金属をメッシュ状に編んだフィルター、天然あるいは合成高分子の多孔質体、または無機・有機物質の焼結体等である。しかしながら、近年は特に精密分析に適用できる均一な細孔を有し、強度の優れたフィルターの需要が高まっている。その理由は、抗原抗体反応のような微量生体成分の分析に際しては、微生物や生体液中に含まれる物質（赤血球、ウイルス等）のように、極めて微細な物質を正確に濾別する必要があるためである（例えば、赤血球を取り除くには $\Phi = 20\mu$ m程度の精度の高い孔が必要）。このような場合においては、濾別機能を優先しても、液相あるいは気相自体の通過が困難では実用的でなく、更に、濾過材自体の耐性も高くなくてはならない。

【0006】また、上記精密分析に用いられる濾過材の場合には、濾過材中に廃液や不純物が滞留したり、目的物質が結合した粒子が細孔内に埋没してしまうと、測定結果の誤差要因となってしまう。そのため、反応容器の濾過材には、その厚みが可能な限り薄く、且つ細孔の口径が均一なものが要求される。しかしながら、従来の濾過材では、このような機能を全て満たすことは不可能であった。

【0007】そこで発明者等は、均一な細孔を有し、使用時における耐性が優れ、目的の反応系に干渉しない濾過材を具備する反応容器の提供を目的とし、鋭意検討した結果本発明を完成させた。

【0008】

【課題を解決するための手段】本願発明は以上の問題点を解決するためになされたもので、下記の請求項1及び請求項2により構成されている。

請求項1：電鍍法によって製造された金属メッシュ（金網）を濾過材として具備することを特徴とする反応容器。

請求項2：直径又は一辺の長さが20 μ m～500 μ mの均一な細孔を有する、電鍍法によって製造された金属メッシュ（金網）を濾過材として具備することを特徴とする反応容器。

【0009】ここでいう電鍍(electrotyping)法とは、電気分解による電着を利用して、鑄型で鑄物をつくるように原型と同じものを精密に複製する周知の方法である。この技術は、既に多くの分野で応用されており、特に近年は、精密電子部品を製造する分野、例えばプリン

ト配線板の製造方法(特開平2-159789号、特開平6-152105号等)に適用されている。本願は、この方法によって、特定の厚みと特定の口径からなる細孔を有する金属加工品を製し、これを濾過材として具備する反応容器に関するものである。発明者が種々試行錯誤して検討したところ、電鍍(electrotyping)法により製作した金属メッシュ(金網)を濾過材として使用すれば、他の濾過材と比較して反応容器内の微粒子の濾別(捕捉)を的確に行うことができることが判明した。

又、電鍍法で製作される金属メッシュ(金網)は、直径又は一辺の長さが、 $20\mu\text{m}$ ～ $500\mu\text{m}$ の範囲が、均一なものとして得られやすい。

【0010】次に、この濾過材の製造方法について簡単に説明する。

①まず、要求される濾過材の形状(全体のサイズ、細孔のサイズ等)をドライフィルムタイプのフォトレジストに、例えばコンピューターによって精度良く、精密に作図する。

②このフォトレジストを例えば表面平均粗度合が $0.08\sim 0.10\mu\text{m}$ に調製された適当な厚みのステンレス板(具体的にはSUS 304等)の陰極表面にラミネートする。

③次いで、ネガフィルムを用いて感光・現像し、レジストパターンを該表面に形成する。

④公知の界面活性剤で洗浄後、更に純水で仕上げる(洗浄する)。

⑤これを例えばワット浴タイプに浸漬し、レジストパターンの無い部分のステンレス板表面を活性化し、陰極電源を接続する。所定の電流密度を印荷し、規定の膜厚になるまで電鍍を継続する。

⑥所定の膜厚が形成されたら電源を切り、ステンレス板を浴槽から取り出す。

⑦このステンレス板を充分水洗し、ステンレス板に形成されたニッケル電鍍メッシュを物理的に引き剥がし、必要な加工(例えば目的とする大きさに打ち抜く等)をして目的とする濾過材を製造する。

【0011】前記ワット浴とは、硫酸ニッケル、塩化ニッケル、ホウ酸、各種添加剤、ピット防止剤、 $\text{pH}3.0\sim 3.5$ からなるもので、電鍍の条件は、電極が電解ニッケル、温度が $50\sim 55^\circ\text{C}$ 、電流密度を $2.5\sim 4.5\text{A}/\text{dm}^2$ に設定し、攪拌下にて行う。

【0012】前記ワット浴に換え、スルファミン酸ニッケルタイプでも行うことができる。これは、スルファミン酸ニッケル、ホウ酸、各種添加剤、ピット防止剤、 $\text{pH}4.0\sim 4.8$ からなるもので、電鍍の条件は、電極がデボライズド(複極)ニッケル、温度が $48\sim 50^\circ\text{C}$ 、電流密度を $2.0\sim 4.8\text{A}/\text{dm}^2$ に設定し、攪拌下にて行うこともできる。

【0013】このようにして製造された濾過材は、最小径で $20\mu\text{m}$ 程度のもので製造することができる。特

に $25\mu\text{m}\sim 500\mu\text{m}$ までの範囲内で適宜製造でき、また、濾過材の上面と下面でも上記の範囲内で均一な孔を有する濾過材を形成することが可能である。その厚みも $1\mu\text{m}$ 以上、特に $2\mu\text{m}\sim 500\mu\text{m}$ まで適宜製造することができる。材質については、電鍍法に適用できる金属であれば良く、ニッケル、銅、亜鉛、アルミ、チタン、コバルト、金、銀等といった金属からなる濾過材を得ることができる。

【0014】前記濾過材を更に白金、金、銀等の非電解及び電解メッキを通常的手段によって施すこともできる。特に、本願の濾過材は金属であるため、厚みが数 μm と極めて薄くとも、使用時の耐性は、従来の合成高分子のような材質とは比較にならないほど強度的に優れている。また、厚みが薄いので、焼結体フィルターのように、廃液が濾過材に残存することがないので、汚染防止にも優れている。

【0015】また、細孔の口径はコンピューターによる作図によって規定・作成できるため、全ての孔が均一の孔径を有し、目的とする物質を的確に濾別でき、且つ粒子の埋没も防止できるので、測定結果の信頼性を高めることができる。

【0016】更に、電鍍法に適用できる金属が広範囲であるので、特に免疫学的反応に影響を与えることのない適切な金属を選択しうるものである。

【0017】

【発明の実施の形態】このようにして製造された濾過材を、従来公知の反応容器の濾過材に適用する。反応容器は、ガラスまたは高分子からなる液体を収容し得る容器であり、少なくとも廃液が通過する部位に前記濾過材を適当な手段(圧着、嵌合等)で固定する。本願反応容器(本体の材質は合成樹脂)の一例を図1に示す。

【0018】その使用例としては、例えば、第一の反応後容器上部より空気により加圧し、反応終了後の液を廃液通過孔より排出する。必要に応じて洗浄液が添加され、洗浄液も同様に排出される。引き続き第二の反応が実施される。目的物質が結合した粒子は、濾過材により捕捉され、十分な洗浄、夾雑物のない状況下で第二の反応、信号発現反応が実施される。

【0019】

【実施例】

<実施例1>

濾過材具備反応容器の製造

(1) 細孔の口径が $50\mu\text{m}$ となるように格子図をドライフィルムタイプのフォトレジストに作図した。このフォトレジストを表面平均粗度合が $0.09\mu\text{m}$ に調製されたステンレス板(SUS 304)の陰極表面にラミネートした。次いで、ネガフィルムを用いて感光・現像しレジストパターンを該表面に形成した。界面活性剤で表面を洗浄後、更に純水で洗浄した。これを硫酸ニッケル($350\text{g}/\text{l}$)、塩化ニッケル($45\text{g}/\text{l}$)、ホ

5

ウ酸(35g/l)、添加剤としてのサッカリン(7g/l)、ピット防止剤としてのラウリル硫酸ナトリウム(1g/l)を含むpH3.3のワット浴に浸漬し、レジストパターンの無い部分のステンレス板表面を活性化し、陰極電源を接続した。次いで、電鍍の条件として、電極が電解ニッケル、温度が50~55℃、電流密度を2.8A/dm²に設定し、攪拌下にて電鍍を行った。膜厚が10μmになるまで電鍍を継続した後電源を切り、ステンレス板を浴槽から取り出し、このステンレス板を充分水洗し、ステンレス板に形成されたニッケル電鍍メッシュを引き剥がし、直径7.5mmの円形に打ち抜き、細孔孔径が50μm、厚さ10μmの濾過材(写真参照)を得た。引き続き図に示したサイズの反応容器に、開口部側から上記濾過材を挿入して圧着し、濾過材具備反応容器とした。

【0020】<実施例2>

該フィルター使用による濾過性能比較試験
ヘマトクリット値50%のヒト血液100μlを当該フィルター具備反応容器に添加した後、容器上部より加圧空気で血液をフィルターを通して系外に排出した。次に生理食塩水500μlを反応容器上部より入れ、また加圧空気でフィルターを通して流し出した。さらに生理食塩水で同様の操作を2回繰り返し、最後に蒸留水1mlを容器に入れ、軽く攪拌を10分間実施した。この容器内の1mlを取り出し、分光光度計で波長420nmにおける吸光度を測定しフィルター上に残ったヘモグロビン(赤血球より溶出したもの)量を算出した。10重測定で0.2±0.1mg/dl(Mean±1SD)という結果を得た。対象として前記反応容器に従来の軟質濾過材(ポリエチレン製、厚さ2mm、平均細孔径50μm)を装着したものを用い、上記と同様の操作を行い反応容器中のヘモグロビン残量を算出した。10重測定で10.4±3.2mg/dl(Mean±1SD)という結果を得た。上記の結果から、本願のフィルターは、従来の軟質フィルターと比べ平均細孔径がほぼ同じにもかかわらず、赤血球を完全に通過させることが可能

6

であることが確認された。

【0021】<実施例3>

該フィルター使用によるHBs抗原量測定における性能比較試験

平均粒径100μmのポリスチレンビーズ(積水化学工業製)の10%懸濁液に抗HBs抗体を添加、2時間攪拌後濾過して抗HBs抗体コートビーズを得た。このビーズ5mgを上述の当該フィルター装着反応容器に入れ上開口部をアルミシールで封をした。これとは別に抗HBs抗体に発光物質であるアクリジニウムエステルを標識物質として結合させ標識抗HBs抗体を作製した。この標識物はpH7.5のリン酸緩衝液に希釈し、二次抗体とした。被検液としてHBs抗原陰性及び陽性のヒト血液を用い、測定装置としては全自動発光免疫測定装置(商品名:ルミクイックJIA-FS150、日本電子製)を使用し、以下の操作を行った。なおこの2検体の血中のHBs抗原量はアボット社オースザイムロで測定したところ、検体1では0.0U/ml、検体2では3.0U/mlであった。機械上で使う試薬としては上記のビーズ、二次抗体以外に界面活性剤を含んだ洗浄液、発光させるに必要な過酸化水素水を含んだアルカリ水溶液である発光試薬を調製、使用した。

【0022】ルミクイック機械上にセットされた該フィルター具備反応容器の上部アルミシールを破った後、上記ヒト血清100μlを注入し、37℃で3分間ビーズと反応させ、その後洗浄液で4回洗浄排水を行い、次に二次抗体100μlを容器に注いだ。37℃、5分間の攪拌の後4回の洗浄排水を実施した。引き続き発光測定部に反応容器は自動的に搬送され発光試薬400μlが注入され発光反応が始まる。この発光量をフォトンカウンターで測定し、別に既知量のHBs抗原を含んだ血液を検体として測定した発光量より、当該ヒト血液中のHBs抗原量を定量した。2検体の血液についてそれぞれ10回ずつ測定し表1の結果を得た。

【0023】

【表1】

本発明フィルターを用いた測定

No.	検体1	検体2
1	0.0U/ml	3.2U/ml
2	0.0	3.1
3	0.0	3.2
4	0.0	3.0
5	0.0	3.1
6	0.0	3.1
7	0.1	3.1
8	0.1	3.2
9	0.0	3.1
10	0.0	3.2
Mean	0.02	3.13
SD		0.0675
CV%		2.16

【0024】また、対象として前記反応容器に軟質フィルター（ポリエチレン製、平均細孔径50 μ m、厚さ20mm）を組み込んだものを用い上記と同様の操作を実施* 【表2】
従来のフィルターを用いた測定値

No.	検体1	検体2
1	0.0U/ml	3.4U/ml
2	0.1	2.8
3	0.2	3.3
4	0.0	3.1
5	0.0	3.0
6	0.1	2.7
7	0.0	3.5
8	0.2	3.3
9	0.2	3.0
10	0.1	3.0
Mean	0.09	3.11
SD		0.260
CV%		8.36

【0026】以上から、当該フィルターを具備した容器で測定した結果は従来の軟質フィルターと比べて、測定値そのものはほとんど変わらず（測定系への影響はない）、そのうえ再現性が大幅に上昇していることが確認された。

【0027】

【発明の効果】本願発明の反応容器は以上のように構成したから、濾過材中に廃液や不純物が滞留したり、目的物質が結合した粒子が細孔内に埋没してしまい、測定結果の誤差を生じさせるという従来の問題点を一挙に解決することができる。また、電鍍法によって製造した濾過

40 μ m材は、製造方法自体簡便であり、従来品と比較して強度に優れ、性能を均一にすることができる。更に、目的とする物質の汙別（捕捉）を的確に行うことができるため、広い分野での応用が可能となる。

【図面の簡単な説明】

【図1】反応容器の断面図（拡大）である。

【図2】フィルター平面図（全体図、顕微鏡写真）である。

【図3】フィルターの拡大図（顕微鏡写真、倍率約210倍）である。

【符号の説明】

- 1 反応容器
- 2 金属メッシュ

- 3 廃液通過孔

【図1】

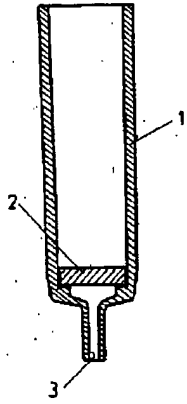

【図3】

図面代用写真

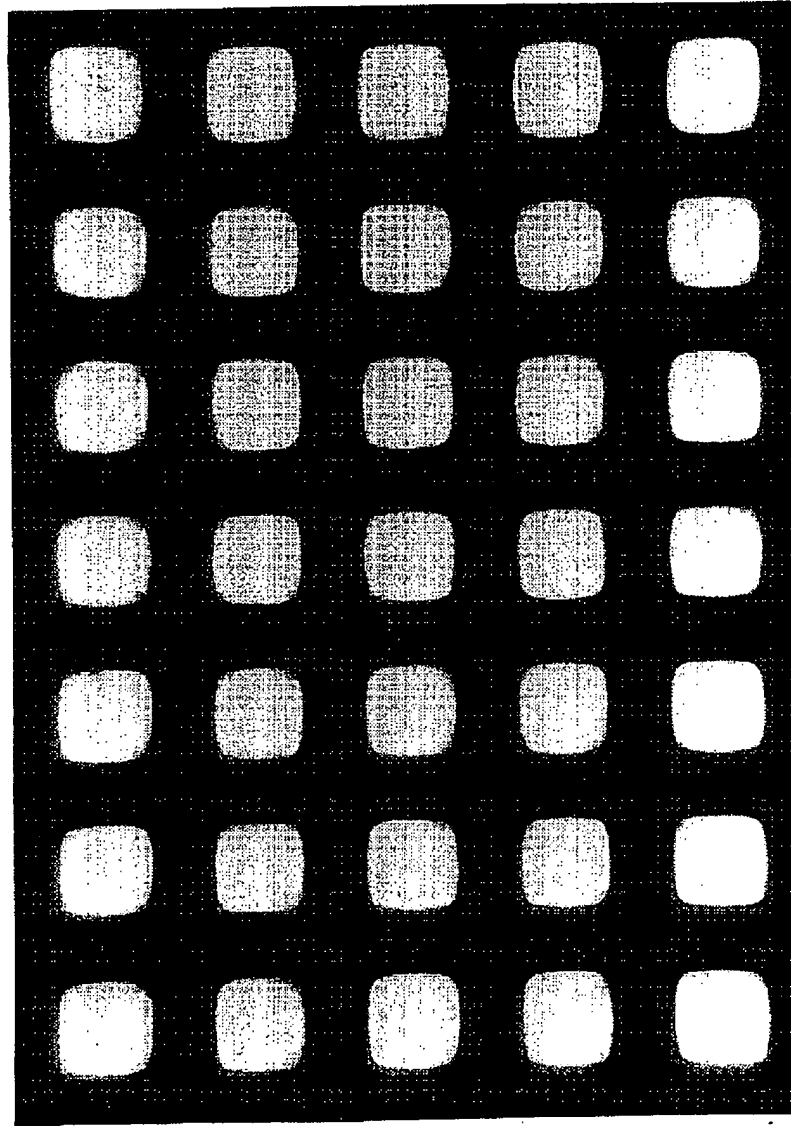

【図2】

図面代用写真

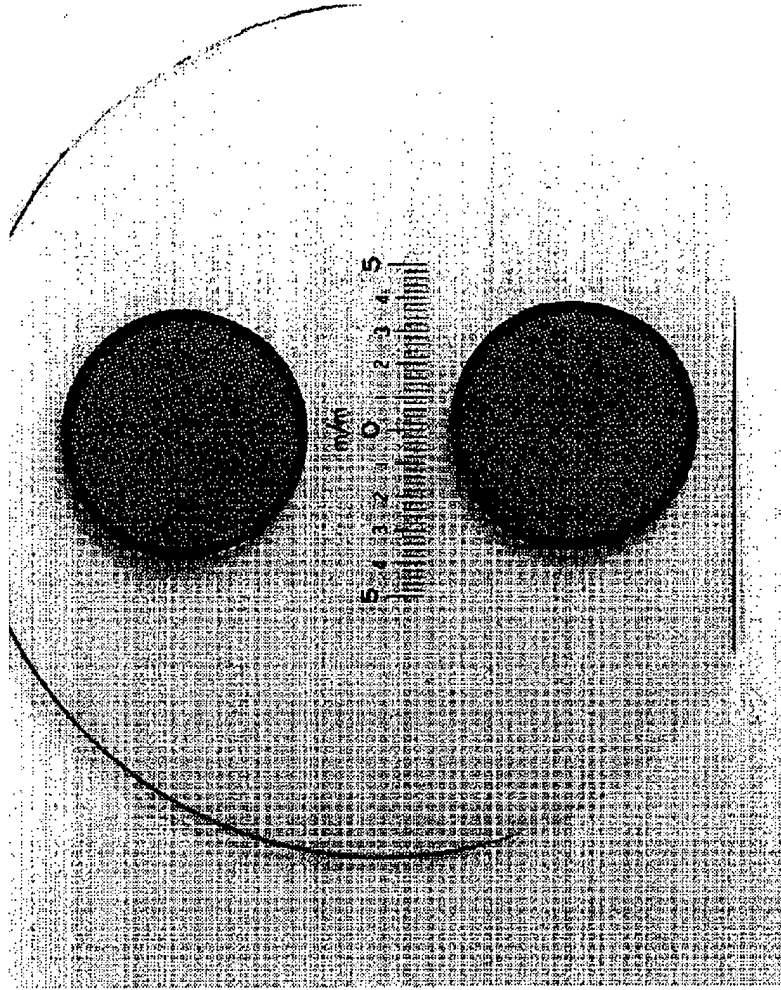

フロントページの続き

(72)発明者 祖父江 晋
東京都千代田区東神田1丁目11番4号 株
式会社ヤトロン内

(72)発明者 中塚 陽子
東京都千代田区東神田1丁目11番4号 株
式会社ヤトロン内

(72)発明者 工藤 勝弘
東京都中野区荒井1-1-5-902

(72)発明者 和田 辰男
神奈川県海老名市柏ヶ谷600-5 ニュー
ハイツ東建ハイツ406